

ナニワ規格シャックル:BAシャックル

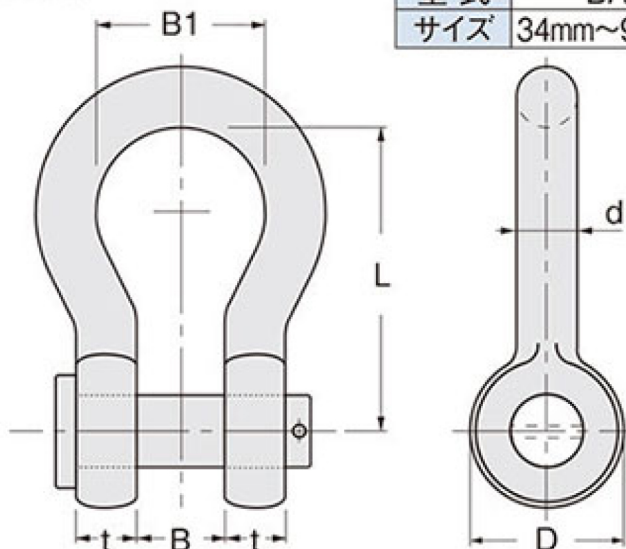

■寸法図



型式	BA
サイズ	34mm~90mm

( ) 寸法はJISに準ずる 単位: mm

呼び	使用荷重		t	d (本体径)	B (口幅)	B1 (内径)	D (頭径)	L (長さ)	穴径	ピン径	ねじ径	重量(kg)		
	tf	kN										BC	BB	BA
6	0.2	1.96	6	8	11	20	17	36	9	8	M8	0.06	—	—
8	0.35	3.43	8	10	14	25	21	45	11	10	M10	0.13	—	—
10	0.6	5.88	10	12	17	30	25	54	13	12	M12	0.21	(0.35)	—
12	0.9	8.82	12	14	20	35	32	63	16	15	M14	0.36	(0.38)	—
14	1.2	11.76	14	16	24	40	36	72	18	17	M16	0.5	(0.56)	—
16	1.5	14.7	16	18	26	45	40	80	20	19	M18	0.74	(0.83)	—
18	2	19.6	18	21	29	53	45	95	22	21	M20	1.1	(1.23)	—
20	2.5	24.5	20	23	31	58	50	104	25	24	M24	1.6	1.8	—
22	3	29.4	22	26	34	65	55	117	27	26	M24	2.0	2.2	—
24	3.6	35.28	24	28	39	70	62	126	31	30	M30	2.6	3.0	—
26	4.2	41.16	26	30	41	75	66	135	33	32	M30	3.1	3.6	—
28	4.8	47.04	28	32	43	80	70	144	35	34	M33	3.9	4.4	—
30	5.4	52.92	30	34	45	85	75	153	37	36	M36	4.6	5.3	—
32	6.2	60.76	32	37	48	93	80	167	39	38	M36	6.1	6.8	—
34	7	68.6	34	39	50	98	85	176	41	40	M39	7.2	8.1	8.0
36	8	78.4	36	42	54	105	90	190	43	42	M42	8.5	9.8	9.0
38	9	88.2	38	44	57	110	95	198	47	46	M45	10.1	11.5	11.4
40	10	98	40	47	60	118	100	212	49	48	M48	12.5	14.2	14.2
42	11	107.8	42	49	63	123	105	220	53	51	M48	—	15.9	15.2
44	12	117.6	44	51	66	128	110	230	56	54	M48	—	18.8	17.0
46	13	127.4	46	53	68	133	115	240	58	56	M48	—	20.0	18.6
48	14	137.2	48	55	72	138	120	248	60	58	M56	—	22.9	20.0
50	15	147	50	57	75	143	125	257	62	60	M56	—	26.4	24.9
55	18	176.4	55	62	83	155	138	280	67	65	M64	—	34.8	32.0
60	22	215.6	60	69	90	178	150	310	72	70	M64	—	42.6	41.0
65	26	254.8	65	75	98	188	164	338	79	77	M72	—	55.6	53.0
70	30	294	70	81	105	202	178	360	85	83	M80	—	73.7	71.0
75	35	343	75	87	112	218	192	387	92	90	M80	—	87.0	81.0
80	40	392	80	93	120	232	206	414	98	96	M90	—	108.0	100.0
85	45	441	85	99	128	248	220	440	104	102	M90	—	126.0	113.0
90	50	490	90	104	135	260	232	473	110	108	M100	—	152.0	144.0